

TOP VIEW

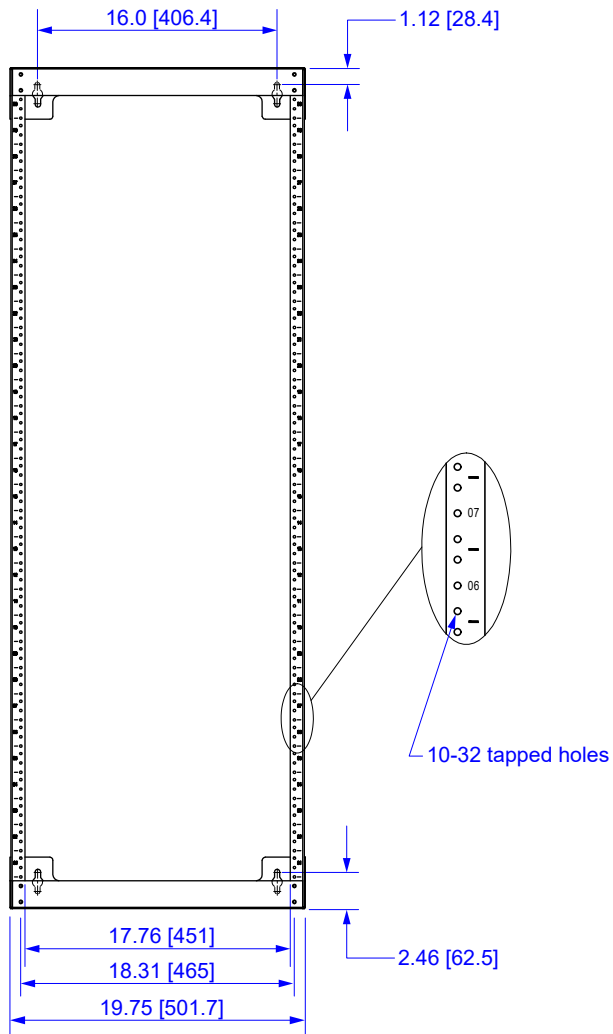

FRONT VIEW

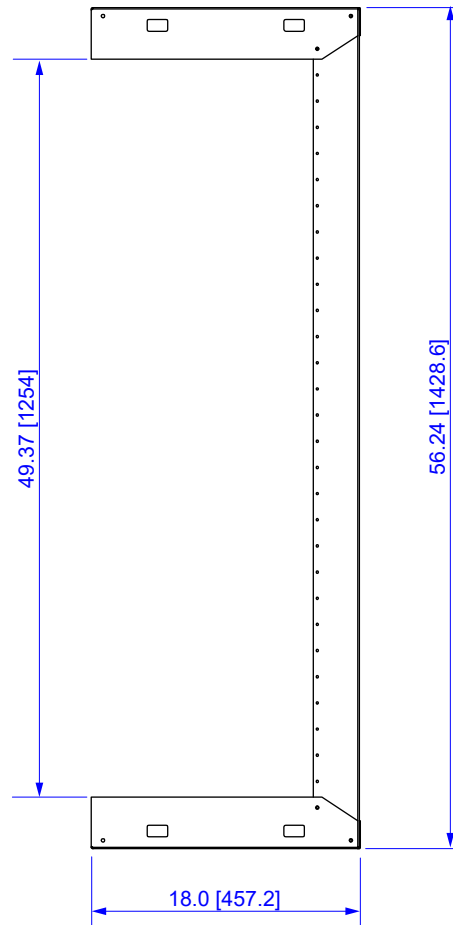

SIDE VIEW

All dimensions in inches [mm]

COMPLIANCE	ANSI/EIA RS-310D IEC60297-2 DIN41494; Part 1 DIN41494; Part 7
LOADING CAPACITY	125 lbs.

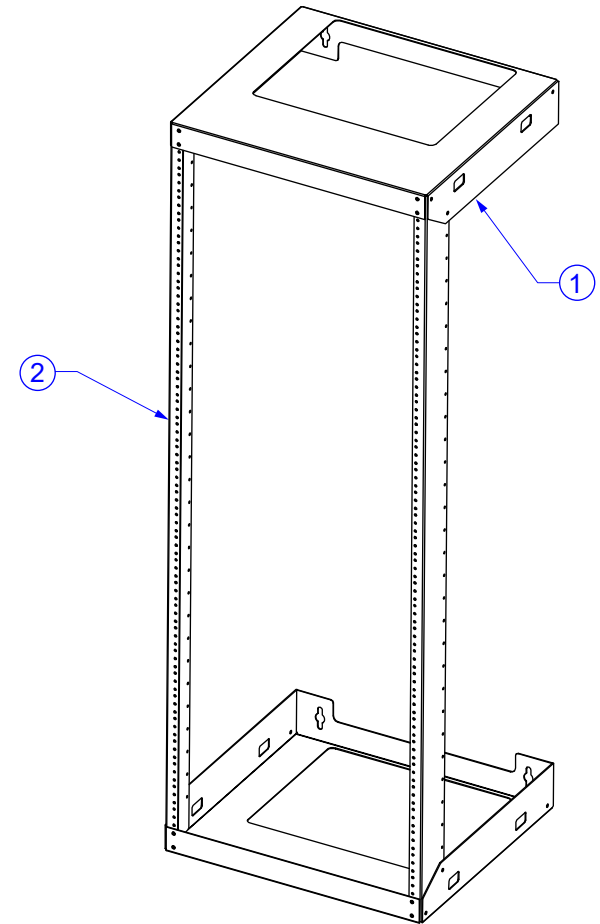

No.	Description	Gauge	Qty
1	Top / Bottom	16	2
2	Mounting Rail	14	2

ITEM NO.	VW5-5301	<b>VERICOM</b>	
DESCRIPTION	30U WALL MOUNT RACK		
DATE	SCALE	SHEET	REV
12/04/2020	none	1 of 1	